

GCBSR ENTRY FORM

Schooner name: _____ Former name/s: _____
Sparred length (DL): _____ Home port: _____ Arriving in Baltimore from: _____
Contact person: _____ Mobile phone: _____
Day phone: _____ Evening phone: _____ Fax: _____
Email: _____ Web site: _____
Captain (if different): _____ Owner (if different): _____
Permanent address: _____
Seasonal address & dates: _____
Shore side emergency contact during race week: _____
Day phone: _____ Evening phone: _____ Mobile phone: _____

CREW

Please list tentative crew. You will be asked to submit a final crew list at the Skippers' Meeting on Thursday morning.

crew & officers under 21: _____ # crew & officers 21 or over: _____ Total crew & officers: _____
paying passengers under 21: _____ # paying passengers 21 or over: _____ Total paying passengers: _____
Total persons under 21: _____ Total persons 21 or over: _____ Total persons on board: _____

HOSPITALITY

Docking preference: Starboard side to Port side to No preference *If available:* Electric volts/amps: _____
Will you dock at BMC while in Baltimore? No Yes Would you like to be in the same slip at BMC as you were last year? No Yes
While in Baltimore, will you need to take your vessel out of the dock on a regular basis? No Yes
Open to the public? No Yes, Baltimore on Wednesday Yes, Portsmouth on Saturday Yes, Portsmouth on Sunday
Room for volunteers or sponsors for the Parade of Sail? No Yes If Yes, how many? _____

FLOAT PLAN

Day & date of estimated arrival in Baltimore: _____ AM PM
Day & date of estimated departure from Portsmouth: _____ AM PM
If you do not expect to attend race events in both ports, please advise: _____

SAFETY EQUIPMENT

EPIRB VHF GPS SatNav Radar WeatherFax SSB Life raft Dinghy/yawl boat Trysail Storm jib AIS
Other: _____

BOAT DATA

Draft: _____ Beam: _____ Displacement: _____ Hull material: _____ Power: _____
Designer: _____ Design/type/model name: _____ Working sail area (lowers): _____
Builder/rebuilder: _____ Build/rebuild location: _____ Built/rebuilt year: _____
Photo: None Attached Sent to race@schoonerrace.org Bio/press kit: None Attached Sent to race@schoonerrace.org

HOLD HARMLESS

Please read before signing. I agree to abide by the regulations & sailing instructions for this event, &, by signing below, confirm that I have read the Safety Statement & that my vessel conforms in all respects. I hereby agree that neither I nor any of my crew members, cadets or passengers shall hold the Great Chesapeake Bay Schooner Race, Inc., nor any of its personnel responsible for damage, accidents or injuries during the race or related activities; no person shall be aboard my vessel who has not consented to this waiver in his or her behalf. I understand that organizers may transfer to third parties the right to film or tape part or all of the event for eventual license, sale or distribution, & agree that neither organizers nor such third party has any obligation to compensate entrants in any form.

Signed: _____ Title: _____ Date: _____

Check here if you decline permission for us to trade your address with related non-profits (ASTA, ASA, CBF, Mystic). We very seldom share our mailing list.

GCBSR HANDICAPPING DATA

Schooners will be rated under the 1974 Off Soundings Club Rating Rule. Its basis is the amount of theoretical sail area (lowers) you have room for, not your actual inventory. Owners are reminded that boats as built always differ from their line drawings — we recommend you measure the boat, not her plans. **Even if your handicapping data is on file with us, please complete ALL of this form.**

Schooner name: _____

Completed by: _____ Date: _____

Mainsail rig: Marconi Gaff Unstayed Junk Fully-battened Other

Foresail rig: Marconi Gaff Unstayed Junk Fully-battened Other

Number of masts: _____ **Number of propellers:** _____

Prop type: Solid Feather/Fold

blades: _____

Prop size: _____ x

No engine? Describe towed yawl boat (LWL, prop, draft, etc.):

SPECIAL DOCKING NEEDS? Please explain: _____

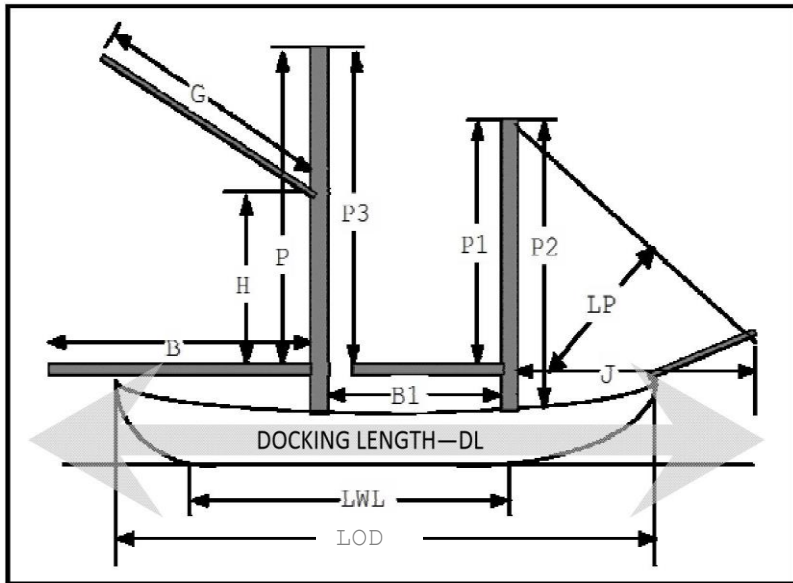

Note: We may make allowances for excess displacement, oversized props, etc. The Race Committee reserves the right to adjust ratings to promote competitive racing.

	<i>Please state measurement in feet and decimal feet (14'3" would be 14.25')</i>	Feet
LOD	Length on deck. (This may be on your documentation as "LOA.")	
LWL	Waterline length.	
Beam	Maximum beam (measured at widest point of hull, excluding rub rails on other protrusions from the fair surface of	
DL	Docking length (Total Sparred Length; We need to know how much space you will take up!)	
B	Distance from fair extension of aft side of mainmast, sail track or groove to aftermost position to which mainsail clew can be extended, or inner edge of boom black band.	
B1	Distance at deck between forward side of mainmast & after side of next mast.	
J	Distance from forward side of mast at deck to intersection of foremast stay on which foremast headsail can be carried, with top of bowsprit, if used, or top of rail including cap.	
P	(Marconi/Bermuda Main ONLY!) Distance from fair extension of top of boom track when touching lowest point of gooseneck to top of main halyard sheave.	
P2	Distance from intersection of forward face of mast with centerline of main deck to intersection of forward face of mast (or topmast) with centerline of uppermost headstay or strop carrying highest headsail.	
P1	Perpendicular measured along after side of mast from highest point on foremast, or fore topmast if fitted, or from underside of highest triadic stay if present, measured to the top of the foreboom when at the lowest position of the	
P3	Perpendicular measured along after side of mast from highest point on mainmast, or main topmast if fitted, or from underside of highest triadic stay if present, measured to the fair extension of the top of the foreboom with the mainmast when the foreboom is at the lowest position of the gooseneck.	
G	Extreme length of gaff, when lying on top of boom, to the mast proper.	
H	Luff. Perpendicular measurement along after side of mast, from throat cringle of sail to upper side of boom.	
3 & 4 masted schooners only:		
B2	(3 & 4-masters only) see B1 above for third mast.	
B3	(4-masters only) see B1 above for fourth mast.	
P4	(3 & 4-masters only) see P1 above for third mast.	
P6	(4-masters only) see P1 above for fourth mast.	
P5	(3 & 4-masters only) see P3 above for third mast.	
P7	(4-masters only) see P3 above for fourth mast.	

GCBSR SHIRT ORDER

Schooner name: _____

Contact person: _____ Phone: _____

This year you will receive top-quality, heavy-weight, long-sleeved, crew-necked tees, delivered to you in Baltimore. Prices include tax. Only sizes listed are available. They make great souvenirs or gifts. Additional race merchandise, including short-sleeved shirts, sweatshirts, hats, etc., will be available at the parties in Baltimore and Portsmouth.

Official race shirts serve as your admission ticket to all events, so order at least as many shirts as you have persons on board. Shirts are \$20/ea. If ordered by 09/07, and at least 4 shirts, they will have your vessel's name printed on the right sleeve.

Shirt Size	Qty
Small	
Medium	
Large	
XL	
XXL	
3XL	
Total Qty Ordered	
x \$20 per shirt	
Total Shirt Order	

GCBSR PAYMENT

Entry fee of **\$1.50 per foot of LOD (if rcvd before Aug. 15, \$2.00 after)**..... \$ _____

Surcharge for paying passengers: # _____ @ \$10 per passenger \$ _____

Total shirt fees \$ _____

Optional tax-deductible donation** to support the race \$ _____

Total amount remitted \$ _____



If form will be mailed & you prefer to pay by check, please make it payable to GCBSR.

Mail to:
GCBSR
P.O. Box 127
Mobjack, VA 23056

**** Donations over \$250 will be listed under your schooner's name on promotional materials unless you specify otherwise:**

Measurement Examples

